

XTOOL | Safety Set

用户手册

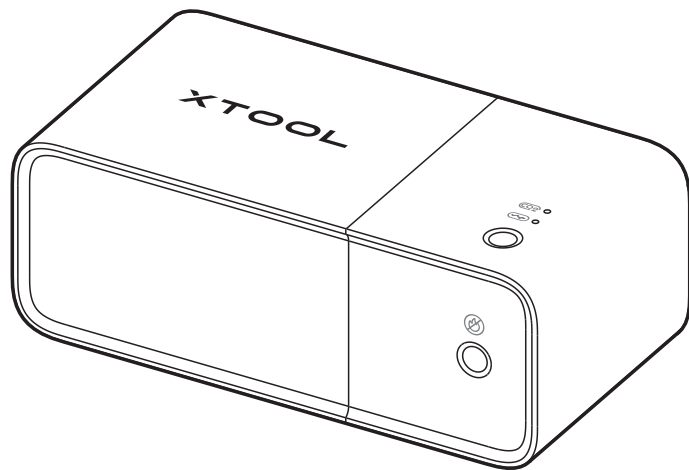

概述	01
规格参数	01
物料清单	02
认识火焰安全装置	03
安装火焰安全装置	04
安装气瓶	04
使用火焰安全装置	06
一键灭火	07
更换气瓶	08

概述

xTool 火焰安全装置是专为桌面级激光加工产品设计的一款安全辅助工具，当它从激光设备收到火焰信号，会自动完成从监测到灭火的全过程。

规格参数

工作温度	0°C~35°C
存储温度	0°C~45°C
支持的最大加工空间	0.13 立方米

物料清单

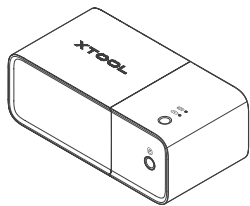

控制盒

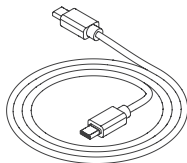

USB 线

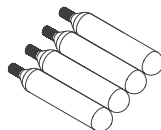

气瓶

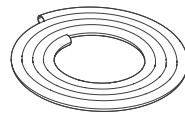

气管

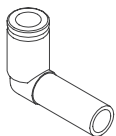

气管接头



用户手册



安全说明

认识火焰安全装置

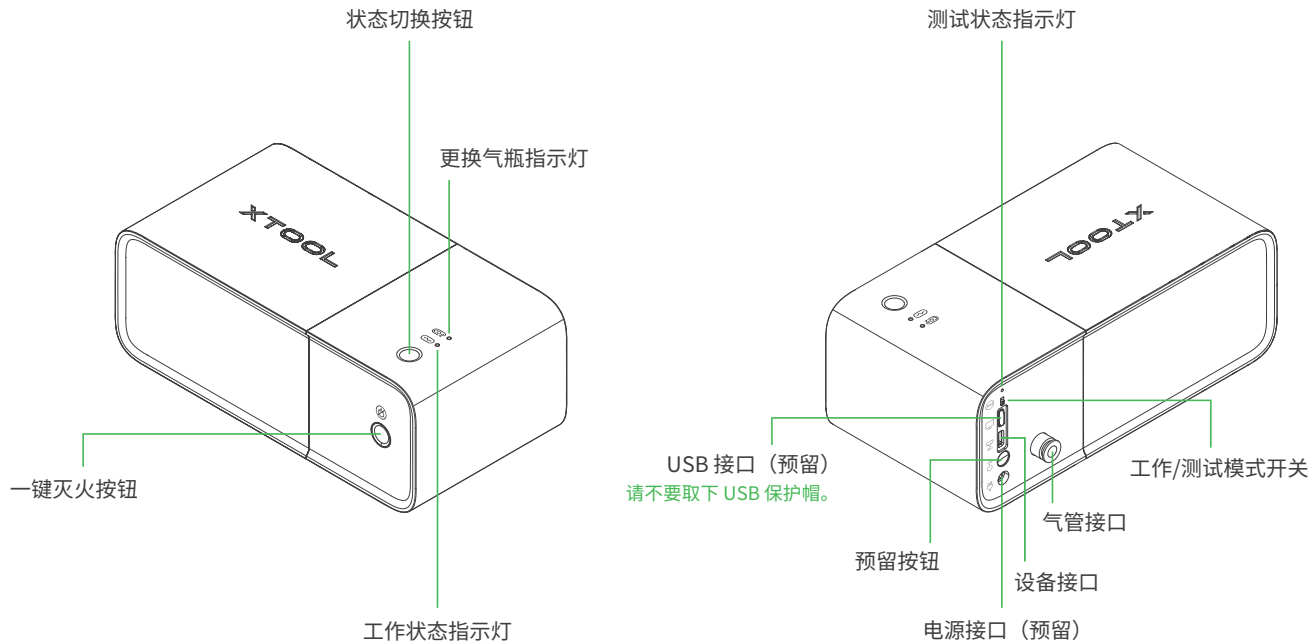

安装火焰安全装置

火焰安全装置的安装需以实际设备为准。

如使用 xTool 设备，可访问 makeblock.com/cn/docs 或扫描下方二维码查看火焰安全装置详细的安装步骤。



makeblock.com/cn/docs

安装气瓶



安装气瓶前, 请先取下 USB 线, 切断火焰安全装置与机器的连接, 避免在安装气瓶过程中误触一键灭火按钮, 导致机器进入工作模式。

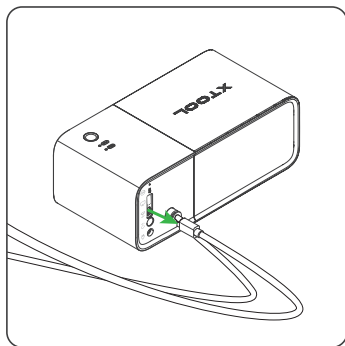

取下 USB 数据线

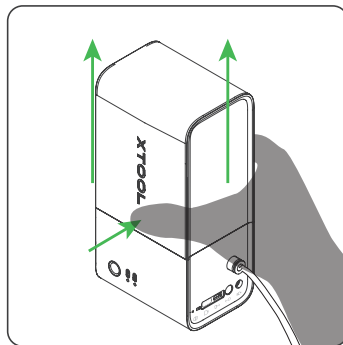

捏住盒子，然后向上拉

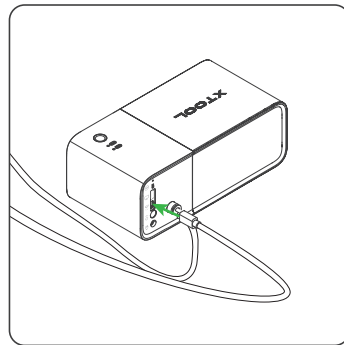
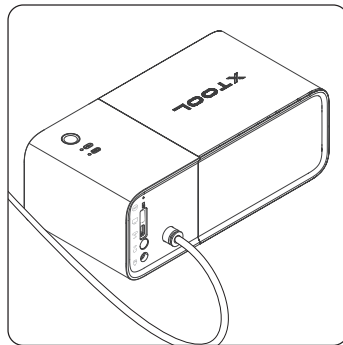
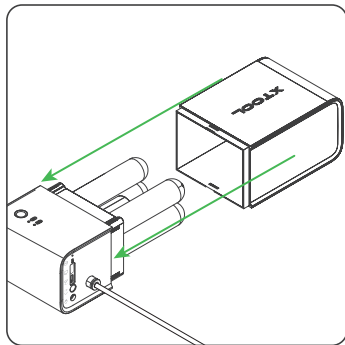
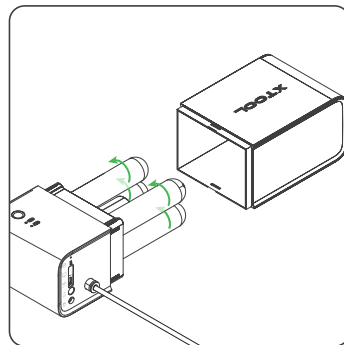

连接 USB 数据线

使用火焰安全装置

进入工作模式

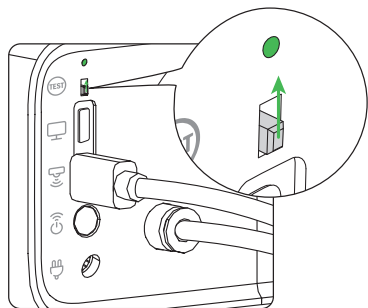

拨动开关至工作模式

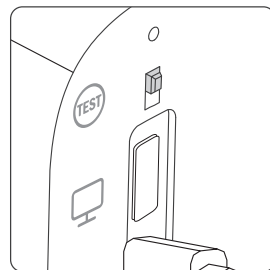

熄灭

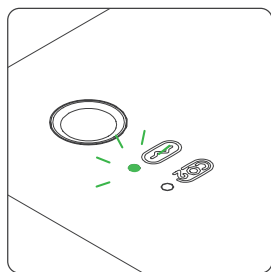

闪烁

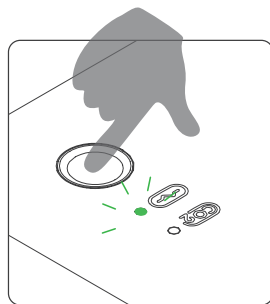

按下

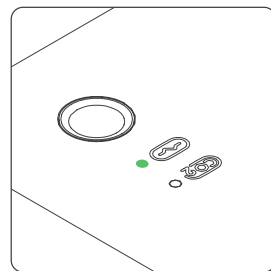

绿色常亮，进入监测状态

一键灭火

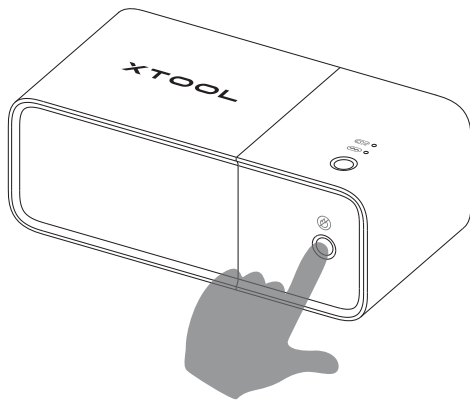

工作模式下,如发现火焰,需手动进行灭火,你可以按下一键灭火按钮手动触发灭火动作。

灭火过程中,气体会分两次喷射,间隔 20s 左右,请等待灭火过程结束再触碰控制盒。

灭火动作一旦触发则无法取消,请谨慎操作。

更换气瓶



- 如火焰安全装置执行过灭火动作, 换气瓶指示灯亮, 需更换气瓶才可继续使用。气瓶需另行购买。
- 更换气瓶前, 请先取下 USB 线, 切断火焰安全装置与机器的连接, 避免在更换气瓶过程中误触一键灭火按钮, 导致机器进入工作模式。

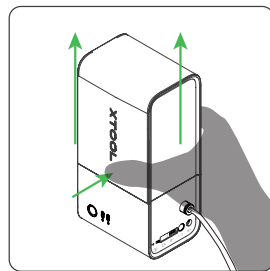
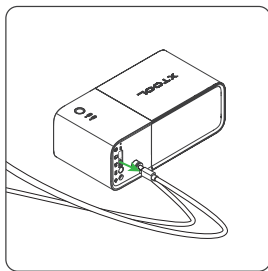
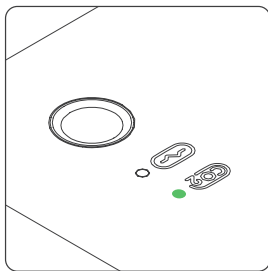

捏住盒子, 然后向上拉

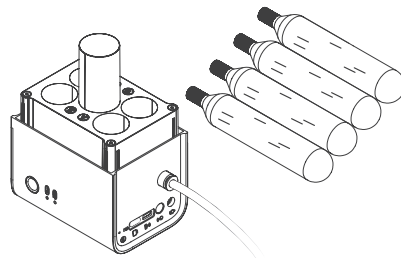
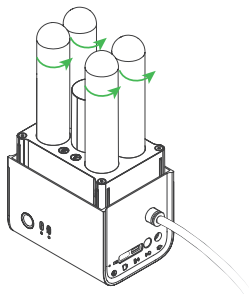

■ 设备加工空间 ≤ 0.065 立方米, 可以选择更换 2 个或 4 个气瓶

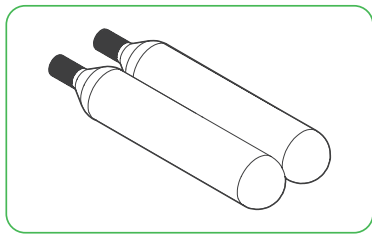

使用 2 个气瓶时请将其安装在一条对角线上, 例如, 都安装在孔 A, 然后在另外一条对角线上的两个孔位安装空气瓶。

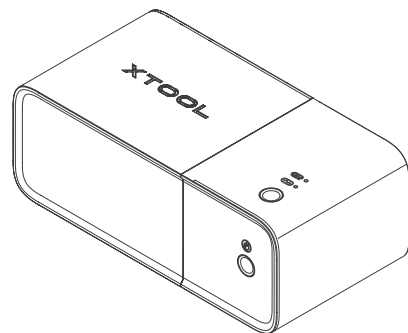
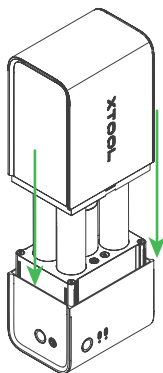
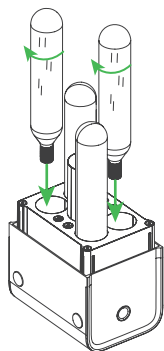
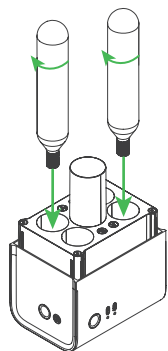

■ 0.065 立方米 < 设备加工空间 ≤ 0.13 立方米, 需使用 4 个气瓶

